

REVISIONS	
ISS	DESCRIPTION \ DATE

RoHS COMPLIANT

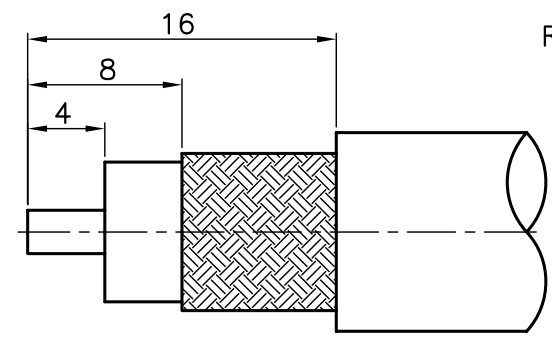

RECOMMENDED
CABLE STRIPPING DIM'S

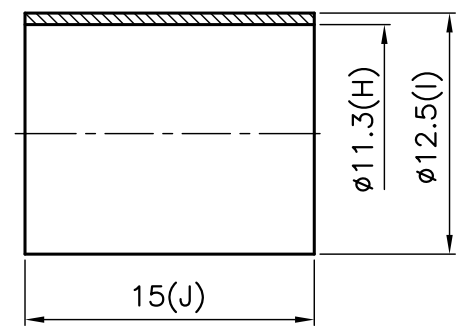
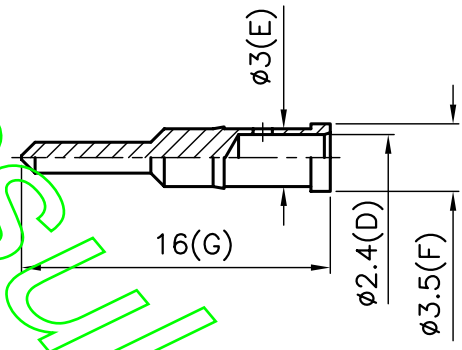
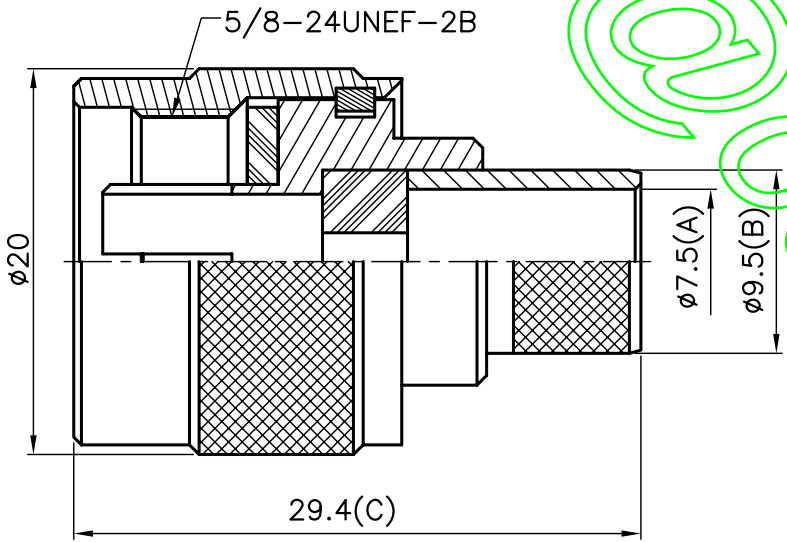

1. CRIMPED FERRULE
HEX CRIMP SIZE .429"
2. CRIMPED CONTACT PIN
HEX CRIMP SIZE .100" OR SOLDER

CONNECTORS CABLES
CCS
SPECIALISTS LTD.

TITLE: N MALE CRIMP
(FOR RG213/U, 214/U)

PART NO: NPCR214

DRAWING NO:

APRD:	UNLESS OTHERWISE SPECIFIED TOLERANCES 0.5-6 = ±0.2 >6-30 = ±0.4 >30-120 = ±0.6 >120-315 = ±1 >315-1000 = ±1.6 ANGLES = ±5°	FERRULE	BRASS	NICKEL	KA/2005/10527 \ KA/2005/60362
CHKD:		CONTACT PIN	BRASS	GOLD	KA/2005/10527 \ KA/2005/30993
DR:		SHELL	BRASS	NICKEL	KA/2005/10527 \ KA/2005/60362
DATE: 09/09/09"		C RING	BRASS	NONE	KA/2005/10527
SHEET: .	UNIT: mm	GASKET	RUBBER	RED	KA/2005/10530
SCALE: 2.5/1		BODY	BRASS	NICKEL	KA/2005/10527 \ KA/2005/60362
		INSULATOR	TEFLON	WHITE	KA/2005/50918
		BODY	BRASS	NICKEL	KA/2005/10527 \ KA/2005/60362
		NO. DESCRIPTION	MATERIAL	FINISH	SGS REPORT NO